

# Original BMW Accessories.

## Installation Instructions.



### Additional Turn Indicator Retrofit Facelift BMW Z4 (E89)

**These installation instructions apply to cars built up to 03/2013 only**

#### Retrofit kit numbers

63 13 7 303 243      Additional turn indicator left  
63 13 7 303 244      Additional turn indicator right

#### Installation time

The installation time is **approx. 25 minutes**. This may vary depending on the condition of the car and the equipment in it.

#### Important information

These installation instructions are primarily designed for use within the BMW dealership organisation and by authorised BMW service companies.

In any event, the target group for these installation instructions is specialist personnel trained on BMW cars with the appropriate specialist knowledge.

All work must be completed using the latest BMW repair manuals, wiring diagrams, servicing manuals and work instructions, in a rational order, using the prescribed tools (special tools) and observing current health and safety regulations.

#### **If you experience installation or function problems, restrict troubleshooting to approx. 0.5 hours for mechanical work and 1.0 hour for electrical work.**

To avoid unnecessary extra work and/or costs, send an inquiry straight away to the technical parts support team via the Aftersales Assistance Portal (ASAP).

Quote the following information:

- Vehicle identification number,
- Retrofit kit part number,
- A detailed description of the problem,
- Any work already carried out.

Do not archive the hard copy of these installation instructions since daily updates are provided via ASAP!

#### Pictograms



Denotes instructions that draw your attention to dangers.



Denotes instructions that draw your attention to special features.

- ◀ Denotes the end of the instruction or other text.

#### Special tools required

00 9 323, Wedge

## Table of contents

Section	Page
1. Parts list for retrofit kit .....	3
2. Preparatory work .....	4
3. Installation of additional turn indicators .....	5

## 1. Parts list for retrofit kit

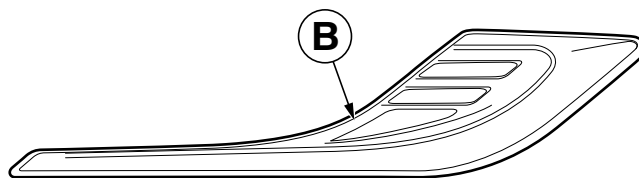
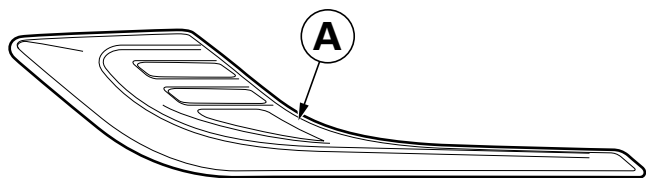

089 0154 Z

### Legend

- A** Additional turn indicator left
- B** Additional turn indicator right

## 2. Preparatory work

### **The following components must be removed first of all**

Remove the additional turn indicators at the front left and right (no longer required)

63 13 200

### 3. Installation of additional turn indicators

☐ Some of the installation steps are shown only on the left-hand side of the car, proceed in the same way on the right-hand side of the car. ◀

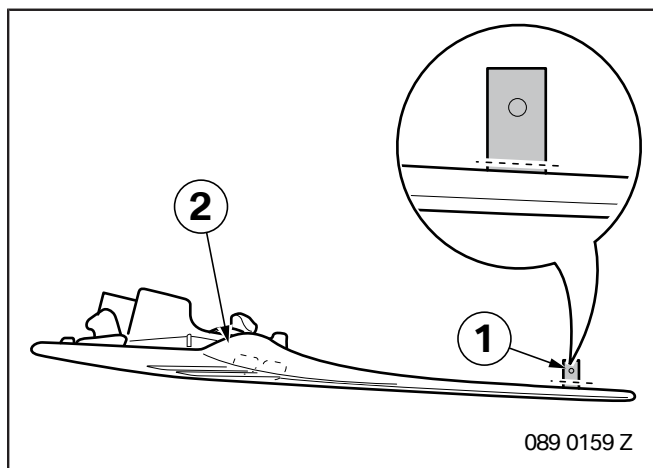

Break off aligning pin (1) flush with additional turn indicator (2).

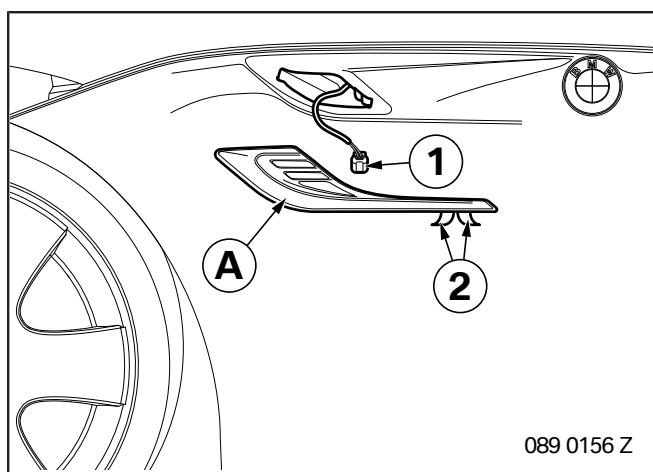

Connect additional turn indicator **A** to plug (1).

Pull off the end of the adhesive backing films just enough to form small tabs (2).

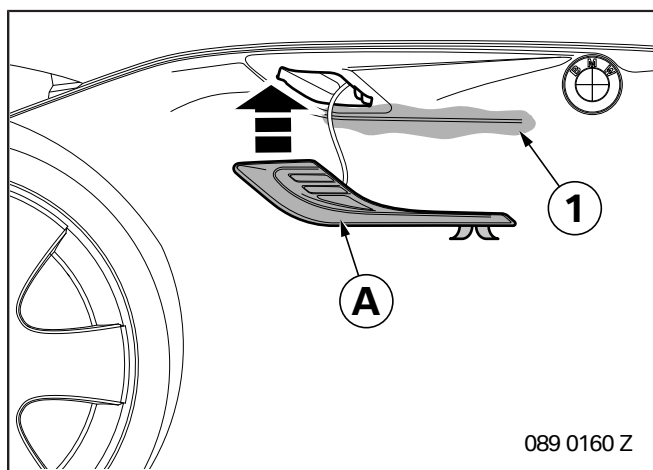

☐ Car surface (1) must be completely dry, clean and free from wax and grease. ◀

Clean car surface (1) with suitable agents.

Clip additional turn indicator **A** into the side panel.

### 3. Installation of additional turn indicators

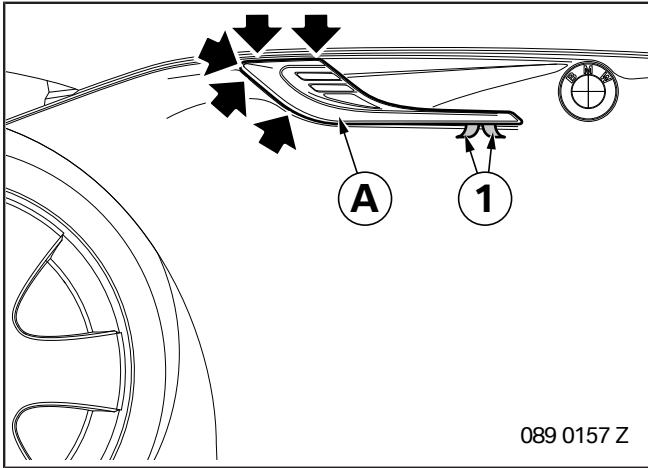

Align additional turn indicator **A** flush with the contour of the side panel.

Carefully pull out protective backing films (1).

Press additional turn indicator **A** against the side panel in the area of the adhesive strips.